

BENDABLE ALUMINIUM CHANNEL FOR LED STRIP

Description:

Introducing our premium aluminum channel, specifically designed to bend and fits LED strip lights up to 0.39" (10mm) in width. It is made from high-quality aviation double-anodized aluminum allowing for superior long-lasting protection. Frosted covers, end caps, and mounting clips can be purchased separately.



Features:

- SKU: AE-1806-BEND-2M
- Bending Radius of 6 inches
- The aluminum alloy is double-anodized to make it even more durable
- Protection against weather conditions, UV radiation, and flames
- You can mount it using double-sided adhesive tape or metal clips



Applications:

- Under-cabinet lighting
- Art accentuation
- Staircase illumination
- Shelf highlighting
- Commercial enhancement

Dimensions:

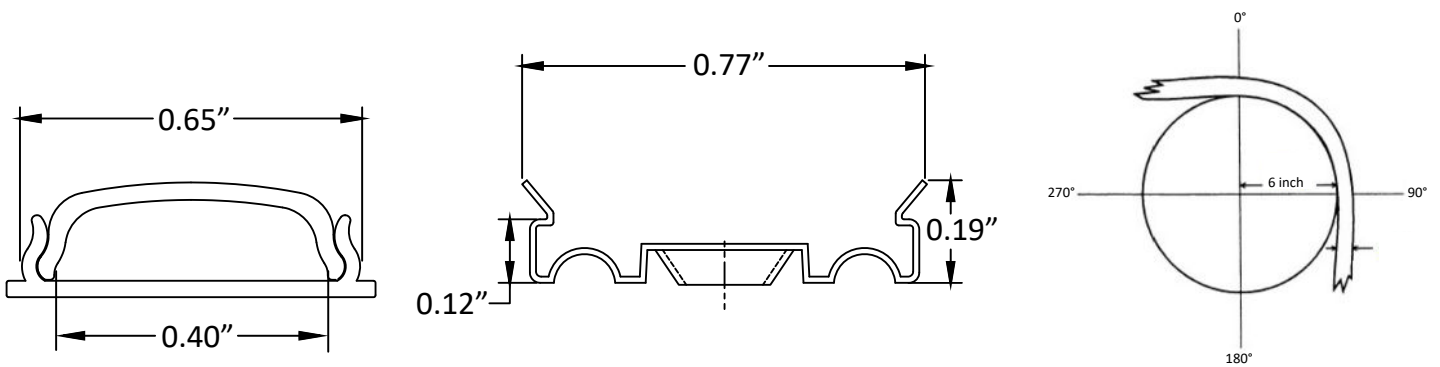

Bending radius 6"

Accessories:

- **End Caps**

1 with hole
 1 without hole
 SKU: AE-1806-CAP
 (Sold separately)



- **Metal Mounting Clips**

2 with hole
 SKU: AE-1806-MNT
 (Sold separately)



Lens:

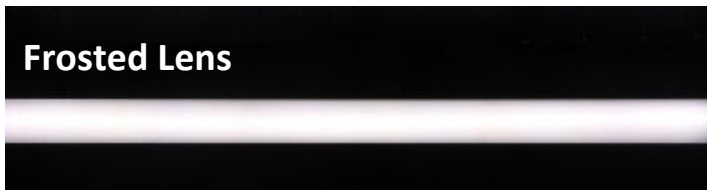

Sold separately
 SKU: AE-1806-BEND-CVR-FRS

Technical Specifications:

Material	Double-anodized Aluminum Alloy
Length	6.4ft
Color	Metallic Gray
Lens (sold separately)	Frosted
Accessories (sold separately)	End cap/ Mounting Clip
Supported LED Strip	Up to 0.39" (10mm)

Installation:

- With Double Sided Tape

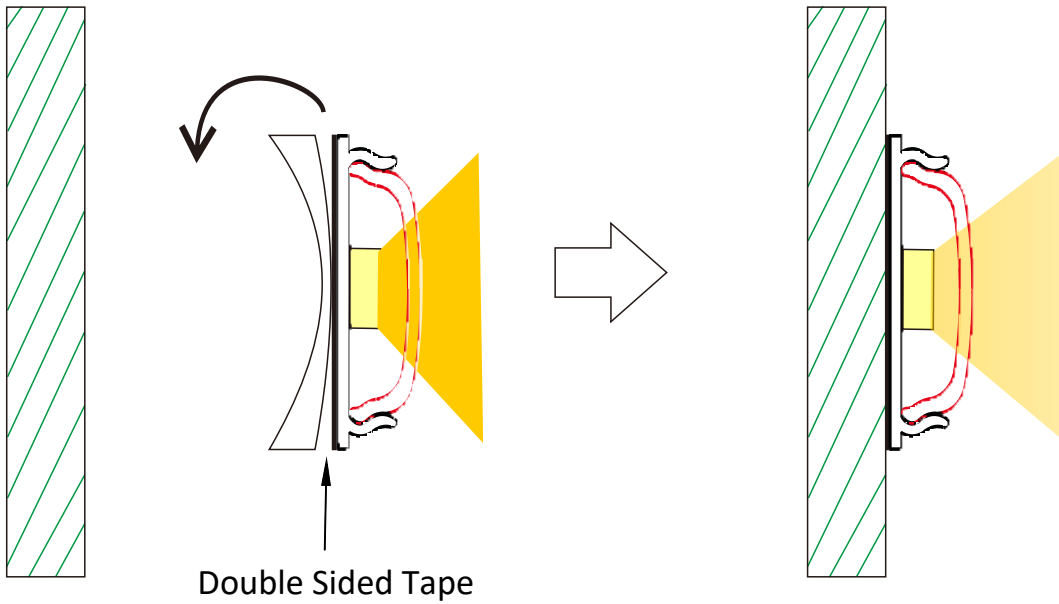

- With Mounting Clip

